



**REAL-WORLD™ RFID.**  
TRUST THE EXPERTS.

## RFID Division Product Portfolio



At Avery Dennison RFID, we focus on the design and manufacture of RFID inlays – a critical link between the tagged item and the hardware, software and databases in an RFID application.

In the real-world, RFID inlays are required to perform on a myriad of materials and in diverse environments, many of which challenge basic RF functionality. For instance, metals cause tags to detune, liquids absorb far field UHF waves and manufacturing or retail settings can be full of wireless RF interference.

Avery Dennison RFID inlay design experts and applications engineers leverage decades of experience to create products that mitigate these real-world challenges.

## Real-World RFID UHF and HF Inlays

Avery Dennison RFID inlays are used across the world in supply chain, retail, aviation, healthcare, defense and many other applications. Below is a sample listing of our products, but check our web site at [www.rfid.averydennison.com](http://www.rfid.averydennison.com) for updates and detailed product information.

### Ultra High Frequency (UHF) Inlay Portfolio

This high performance Avery Dennison UHF RFID products are optimized for a wide range of customer applications across the aviation, healthcare, retail and supply chain markets.

AD-223 Impinj Monza 3



3.74 x .321 in (95 x 8.15 mm)

Best read range performance in the AD-22x family for general purpose use.

AD-224 NXP G2X



3.74 x .321 in (95 x 8.15 mm)

General purpose use with factory programmed and locked unique ID and 240 bits EPC memory with optional 512 bits extra user memory.

AD-230 Impinj Monza 3



2.76 x .571 in (70 x 14.5 mm)

Shortened inlay length to fit into 3 inch labels with strong read range for use with many substrates. Includes good stackability performance.

AD-641 NXP G2X

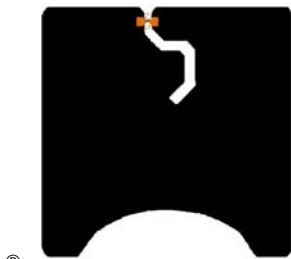

2.76 x 2.76 in (70 x 70 mm)

NXP product developed with uniform radiation pattern for strong performance at almost any angle. Targets carton and pallet asset management with factory programmed and locked unique ID and an option for extra 512 bits of user memory.

AD-240 Impinj Monza 3



3.74 x .212 in (95 x 5.4 mm)

Very narrow antenna width for placement in space restricted applications such as book spines.

AD-805 Impinj Monza 3



.63 x .63 in (16 x 16 mm)

Powerful edge-on reading performance in a very small format. Enhanced read range when placed near metal in certain applications.

AD-814 Impinj Monza 3



.866 x .866 in (22 x 22 mm)

Pharmaceutical and item tagging inlay designed for best edge-on performance. Maximum read range when items are in stacked arrays.

AD-815 Impinj Monza 3



.787 x .394 in (20 x 10 mm)

The smallest form factor in the portfolio. Excellent performer in FCC frequencies for glass vial tracking and best for many substrates in item level tracking in Japanese frequencies.

AD-824 NXP G2X



1.18 x 1.97 in (30 x 50 mm)

Stackable inlay that enables a higher read rate in item level applications like document tracking and retail. Includes factory programmed unique ID with an optional 512 bits user memory.

AD-826 Impinj Monza 3



1.18 x 1.97 in (30 x 50 mm)

Excellent stackability and proximity performance in a small form factor with best in class read range in this format.

AD-827 Impinj Monza 3



.709 x 1.575 in (18 x 40 mm)

One of the most powerful combinations of a small form factor and strong read range for item level and healthcare applications on many different substrates.

AD-828 Impinj Monza 3



.59 x 1.57 in (15 x 40 mm)

Ideal for stackable, close proximity tagging (up to 10mm gapped direct stacking) with strong read rates for retail and item level tracking.

AD-833 Impinj Monza 3



1.5 x 3.68 in (38 x 93.5 mm)

Orientation insensitive design enables no dead spots with powerful read ranges. Ideal for applications with random read angles (RTU totes, baggage on conveyors, pallets, cases, etc.).

AD-840 NXP G2X



1.5 x 3.7 in (38 x 97 mm)

Delivers the strongest read range in the NXP family of inlay products with factory programmed and locked unique ID and an option for extra 512 bits of user memory.

AD-843 Impinj Monza 3



3.75 x 1.5 in (95 x 38 mm)

The RFID industry's first UHF EPC inlay with excellent direct-attach to metal performance and the strongest non-metal read range in the UHF portfolio.

**High Frequency (HF) Inlay Portfolio**

Our new HF family of RFID inlays are ISO 15693 / IEC 18000-3 compliant and designed for multiple applications including media management for libraries.

\*Base product is interchangeable with various chip types. Please contact us for more information.

AD-709 HF NXP SLI\*

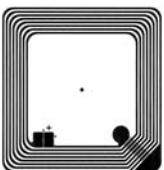

1.85 x 1.85 in (47 x 47 mm)

Designed for media management, this HF tag performs well on books and documents.

AD-714 HF NXP SLI\*

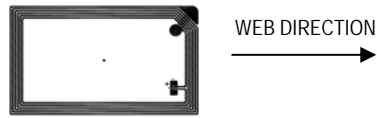

1.77 x 3 in (45 x 76.2 mm)

A high performing media management HF tag with an optimized read range that fits into ISO card form factor.

AD-720 HF NXP SLI\*

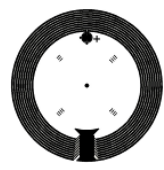

Outside diameter: 1.417 in (36 mm)  
Inside diameter: .827 in (21 mm)

Designed for CD and DVDs, this HF hub tag can be applied to the center ring of a CD/DVD for media management applications.

AD-730 HF NXP SLI\*

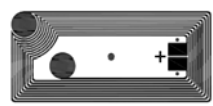

.55 x 1.22in (14 x 31mm) or  
1.22 x .55in (31 x 14mm)

Designed for healthcare applications such as wristbands, asset tagging, medical labels, and pharmaceuticals. Due to the small size, the product may also be applied in markets outside of healthcare such as secure entry devices, e.g. key FOBs.



*All drawings not to scale*  
© Sloop design is a registered trademark design by Avery Dennison

## Durable Product Portfolio (UHF)

The Avery Dennison line of durable RFID tags are designed for great performance and long life in harsh environments. These products are often used to mark locations in warehouses and storage yards.

AD-902 Durable UHF

NXP G2XM



6.18 x 1.38 x .32 in (157 x 35 x 8.2 mm)

Durable, impact-resistant polycarbonate tag tuned for direct attach to metallic surfaces. Ideal for long read range requirements. 240 bits EPC memory. 512 bits of user memory.

AD-904 Durable UHF

Impinj Monza 3



4.875 x 2.25 x .412 in 123.82 x 57.15 x 10.4 mm)

High performance, durable, impact-resistant polycarbonate tag tuned for direct attach to metal.

AD-908 Durable UHF

Impinj Monza 3



5.06 x 1 x .525 in 128.4 x 25.5 x 13.3 mm)

Durable, impact-resistant polycarbonate tag that provides global performance on a wide range of asset tracking applications.

## Why RFID?

Every day Radio Frequency IDentification (RFID) technology helps more businesses across the world reduce costs, increase sales & productivity and even improve healthcare processes to keep patients safe.



Visit [www.rfid.averydennison.com](http://www.rfid.averydennison.com) for more information on our products and solutions, a tour of our technical centers, and to take our free online training program.

Unlike conventional technology, RFID requires no direct line of sight, provides a unique identifier for each tagged item and can collect data from those items exponentially faster resulting in:

- Dramatic reductions in out-of stocks, theft & counterfeiting
- Extraordinary improvements in inventory tracking and work-in-progress processes
- Significantly more reliable tracking, aging & pedigree data

## Best-in-Class Partners & Solutions

We work with an array of industry leaders in tag converting, printer and reader hardware, software and systems integration. This approach allows us to help you select the right combination of partners to meet your specific application requirements.



**REAL-WORLD™ RFID.**  
**TRUST THE EXPERTS.**

Avery Dennison is a participant in Intermecc's *Rapid Start* intellectual property licensing program.



North America  
Europe  
Asia Pacific

866-903-RFID (7343)  
or  
770-967-5709

Email: [rfid.info@averydennison.com](mailto:rfid.info@averydennison.com)

The chart contained herein is only intended as a suggestive guide for preliminary inlay selection. The information contained herein is believed to be reliable but Avery Dennison makes no representations concerning the accuracy or correctness of the data. This product, like any other, should be tested by the customer/user thoroughly under end use conditions to ensure the product meets the particular requirements.